

ITER Vacuum Vessel In-Wall Shields (WBS No. 1.5 (1-B)).

ITER vacuum vessel is double wall construction. Space between outer shell and inner shell is used for water flow and for placing shield structures to stop neutrons escaping the vessel. These shield structures are made of (a) borated steel SS 304 B7 (SS 304 with 2 % boron) and SS 304 B4 (SS 304 with 1 % boron) plates, (b) ferrite steel SS 430 plates and (c) support structure hardware like long bolt rods, spacers, alignment keys etc. made of SS 316 LN (IG). Shield structures made of SS 304 B7 and SS 304 B4 fill up 60 % of volume between two shells while those made of SS 430 fills up 80 % of volume between two shells near toroidal magnetic field (TF) coil locations. Shields made of SS 430 (Ferrite steel) are placed on out board side of vessel near TF coils (between 12 o'clock to 5 o'clock regions except equatorial ports). This is to reduce ripple in toroidal magnetic field by a factor of two. In the design of these shields, number of plates are stacked with spacer in-between to allow required water flow. Actual numbers of plates in each structure vary from one poloidal location to other. This is because of the fact that the space between outer and inner shells is different at different poloidal locations. However, each shield plate is typically $0.3 \text{ m} \times 0.3 \text{ m}$ and thickness is 40 mm. Shields are fixed to poloidal ribs between out/inner shells or to special support to withstand mechanical forces. Welding of SS 304 B4 and SS 304 B7 is not permitted as welding heat changes properties of these materials.

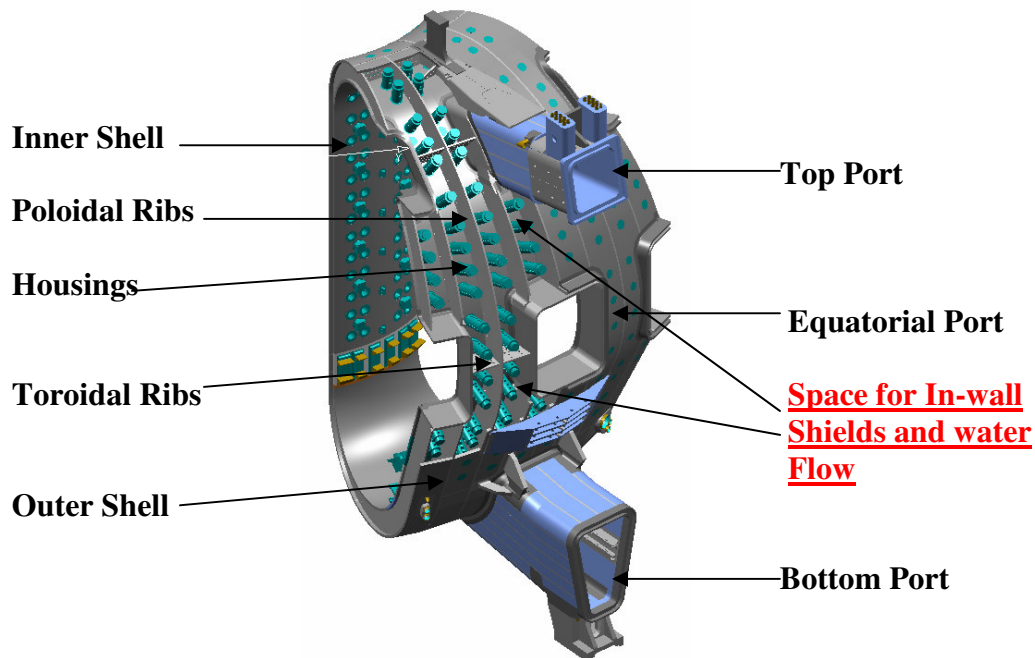

Figure – 1: ITER Vacuum Vessel Sector

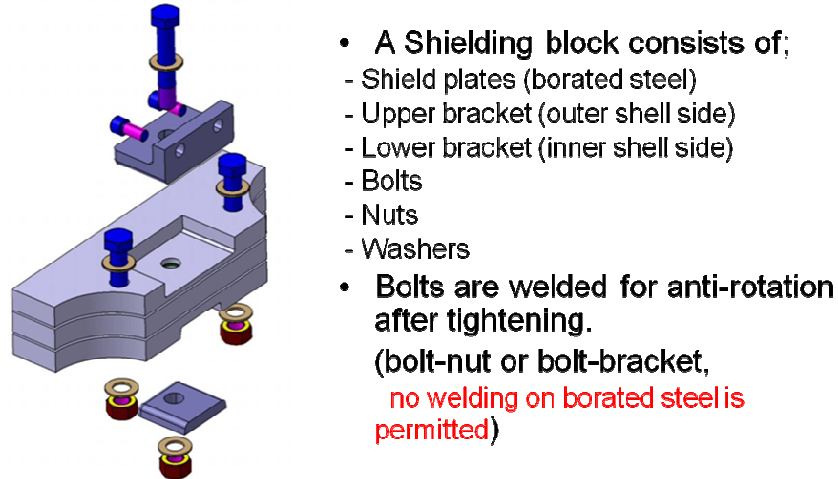

Figure – 2: Typical design of one shield block

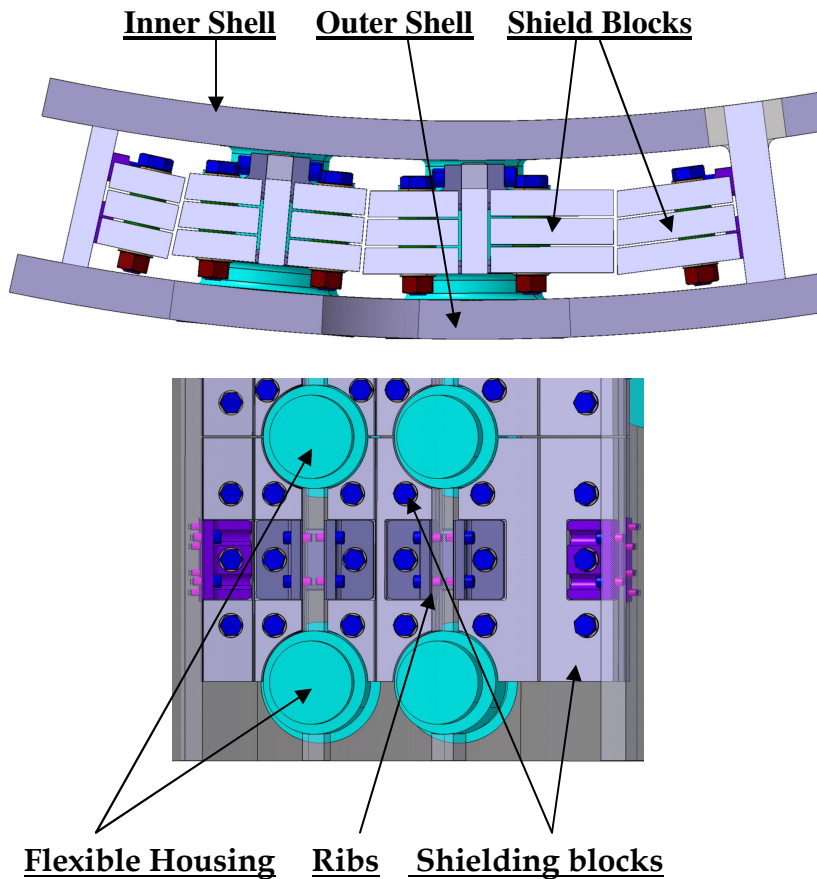

Figure – 3: Mounting scheme of shielding blocks

In-wall shielding is forming the flow channel of the Vacuum Vessel Primary Heat Transfer System (VV PHTS). Pressurized water at 100/200 °C, 1.1/2.4 MPa is passed

through these channels for normal operation and baking of vacuum vessel. Neutron irradiation and hence radiolysis of cooling water is important process to consider. It is also important to note that failure of in-wall shielding may result in decreased cooling performance of vacuum vessel.

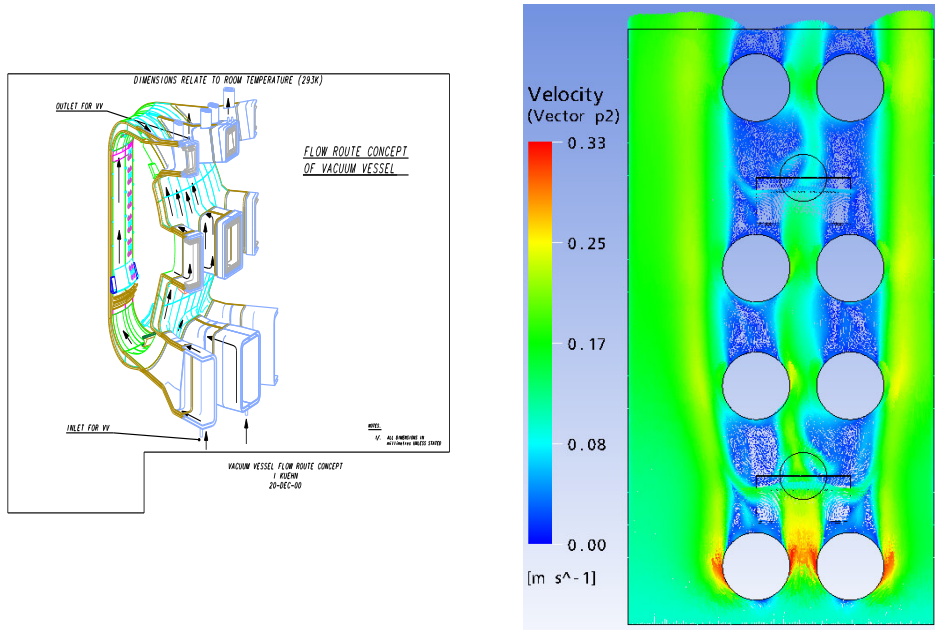

Figure – 4: Water flow path and estimated velocity distribution

Shield structures which are to be placed between two shells of vacuum vessel will be delivered to manufacturer of vacuum vessel. Shield structures for field joint of vacuum vessel will be assembled at ITER site. Total number of shielding blocks is about 6000 but this number depends on actual segmentation and may significantly change. Weight of one block may vary from 50 kg to about 500 kg. Total weight of fabricated components of these shields is 2500 t.