

RF Sources, Monitoring-Control & Auxiliary Power Supplies for ITER

IC H & CD System - WBS: 5.1(3)

The Ion Cyclotron Heating and Current Drive (IC H&CD) system provides two essential functions: plasma heating and on-axis current drive, and several auxiliary functions: plasma and burn control, wall conditioning at full field, plasma breakdown and assisted current rise. A total of 20 MW of RF power is initially required in the frequency band 40-55 Mhz. RF power sources, monitoring-control and auxiliary power supplies for ITER IC H & CD system are within the IN procurement package.

Scope of work

Design, manufacturing, assembly & testing, packaging & shipment, site commissioning & site acceptance of

- One Prototype ICRF Power Source and auxiliary power supplies, including all monitoring and control system, (high voltage supplies of driver and end stage is under HVPS procurement package). This unit will be used as spare;
- Eight series production ICRF power sources and auxiliary power supplies, including all monitoring and control systems, (high voltage supplies of driver and end stage is under HVPS procurement package).

Power per unit

2.5 MW up to VSWR 2.0 is the required power per unit. Such 8 +1 units are in the IN procurement package. No single tube exists as per ITER requirement. Therefore, IN PT are considering two independent chain of amplifiers up to the end stage and a high power wide band combiner to get final output RF power, as shown in fig.1.

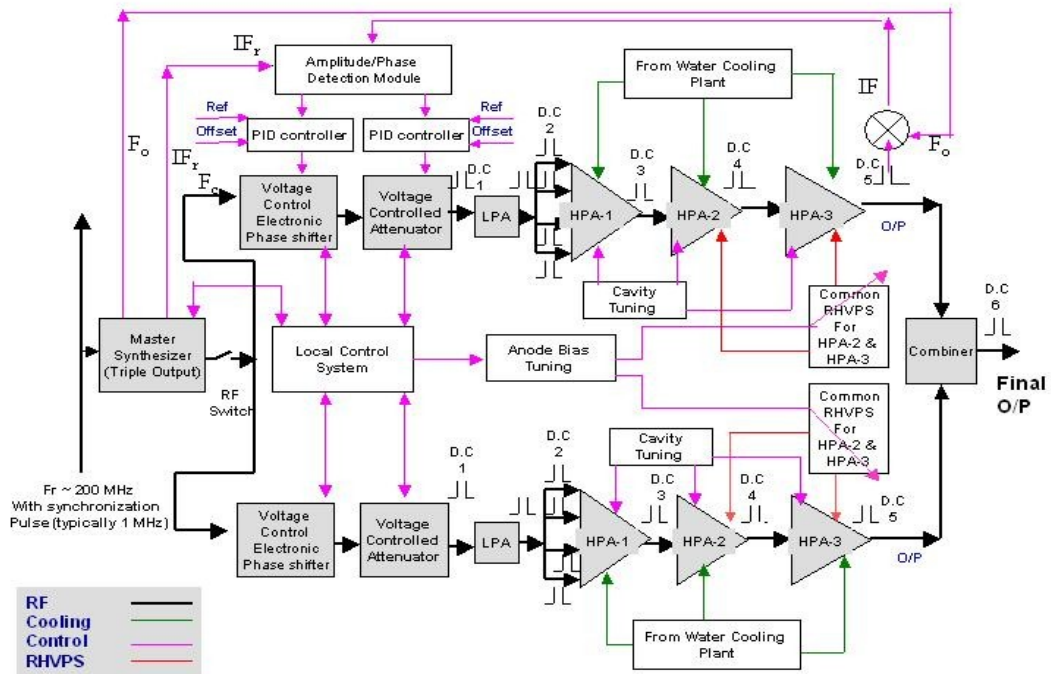

Fig.1: Block diagram of ITER IC RF source

Performance specifications for RF source are tabulated in Table - I

Table - I

Sr. No.	Parameters	Levels & Units
1.	Nominal CW Output Power	2.5 MW, CW
2.	SWR with any phase ($0 - 360^0$)	2.0
3.	Frequency range covered (in step of 1 MHz)	40-55 MHz
4.	Frequency deviation over any central frequency (1 dB point)	± 1 MHz
5.	Power modulation range	2 kW – 2.5 MW
6.	Electrical efficiency	$>65\%$
7.	Phase regulation (w.r.t. a fixed reference)	± 5 degree
8.	Maximum AM frequency	100Hz
9.	Maximum phase modulating frequency	10 kHz
10.	Emergency Power shut down	$<10\mu s$
11.	Level of harmonics (dB on whole frequency band)	< 20

The components/systems considered for the procurement plan:

• RF source chain

Solid state wideband amplifier (LPA)

Tube based 15 kW amplifier (HPA-1)

Tube based 200 kW amplifier (HPA-2)

Tube based 1.25 MW amplifier (HPA-3)

High power combiner

- **Low power RF components/system & Instrumentation**

Master synthesizer (wideband)

RF switch

Power divider

Voltage controlled Phase Shifter & Attenuator

Directional couplers at various power level

RF detection system

- **Auxiliary Power supplies**

Anode power supply for 15 kW stage

Control Grid power supply for 15 kW, 200 kW & 1.25 MW stages

Screen Grid power supply for 15 kW, 200 kW & 1.25 MW stages

Filament power supply for 15 kW, 200 kW & 1.25 MW stages

- **Monitoring & control**

- **Test bed**

High power Dummy load

High power Phase Shifter & Stubs

Tx-line sections

- **Auxiliaries**

- **Diagnostics**